

INSTRUCTIONS &
OPERATING MANUAL
FOR
VERTICAL MAXI GEL & MAXI DUAL
GEL SYSTEM

GENECO-V-MAXI
&
GENECO-V-MAXI-DUAL

GLASS SANDWICH:

A set of rectangular and notched plates are taken together. A pair of spacers is placed between them at the sides. All three sides except notched side are sealed with adhesive tape or agarose gel to make sandwich water tight for casting gel in it. (Using Gel casting unit, gels can be cast easily without any problem of packing and sealing).

OTHER ACCESSORIES:

Accessories like Gel Casting Unit, Gradient Maker and Gel Developing Tray are supplied separately on request.

NOTE:

- In case temperature is not critical parameter, you can use lesser volume of buffer.
- Do not use organic solvents to clean the buffer reservoirs. Use only distilled water and mild detergent.
- Apply a thin film of silicon grease over the rubber gasket every time after use. This will ensure durability of the gasket. If it becomes rigid, replace It with the fresh one.
- While clamping the gel sandwich, tighten the screws only up to the required level. Too much tightening may cause breakage of glass plates.

Vertical Slab Gel electrophoresis Systems, Suitable for a wide range of modern electrophoretic techniques. The Mini Model answers the demand for small, conventional electrophoresis unit for fast, high resolution protein separations in 80 X 70 mm gel. The Midi model is used for electrophoresis in 160 X 140 mm gel. The large dual model is used for 16 X 20 mm gel. These Dual models are versatile ones for running two gels, under similar conditions simultaneously.

These have been designed to perform electrophoresis with,

- As many as 20 samples in Large Model and 40 samples in Large dual models in two gels simultaneously.
- Under Very efficient temperature controlled conditions.
- Cathode chamber cum heat exchanger houses both the electrodes mounted centrally for providing uniform electric field for both the gels.
- A large anode buffer reservoir which also acts as additional heat sink.

SPECIFICATIONS:

MODEL	VERTICAL LARGE MAXI GEL SYSTEM	VERTICAL LARGE DUAL MAXI GEL SYSTEM
Dimensions (LXWXH)	290 X 200 X 210 mm	290 X 220 X 230 mm
Gel Size (Max)	160X 200mm, 1 gel	160 X 200mm, 1 gel
Buffer Required	300 + 600 ml	300 + 700 ml
Electrodes	Platinum	Platinum
Combs -Teflon	20 Well-1.0mm Optional: 0.75 ,1.5mm	20 Well - 1.0mm Optional: 0.75 ,1.5mm & 3.0mm
Spacers- Teflon	1.0mm, Opional: : 0.75 ,1.5mm	1.0mm, Opional: : 0.75 ,1.5mm,3.0mm
Power Required	500 V , 500 mA Max*	500 V , 500 mA Max*
Time Consumed	2 o 6 hrs	2 to 6 hrs

DESCRIPTION AND ASSEMBLY

Slab Gel Systems, both regular and mini models contain almost the similar components and hence the following descriptions are common for both. The System mainly consists of;

- Basic Unit with Lid
- Platinum Electrode Assembly & Connecting Cords
- Combs and Spacers
- Glass plates
- Other accessories
 1. Gel Casting Unit
 2. Gradient Maker
 3. Gel Developing Tray

GLASS PLATES:

Glass Plates used to cast gels are used in a pair such that one is rectangular and the other is notched and both are of the same size and thickness (100 X 100 mm for mini and 190 X 175 mm for regular gels and 4.0 mm thick). They are of good quality, scratch free, undulation glass, and bubble free and heat resistant.

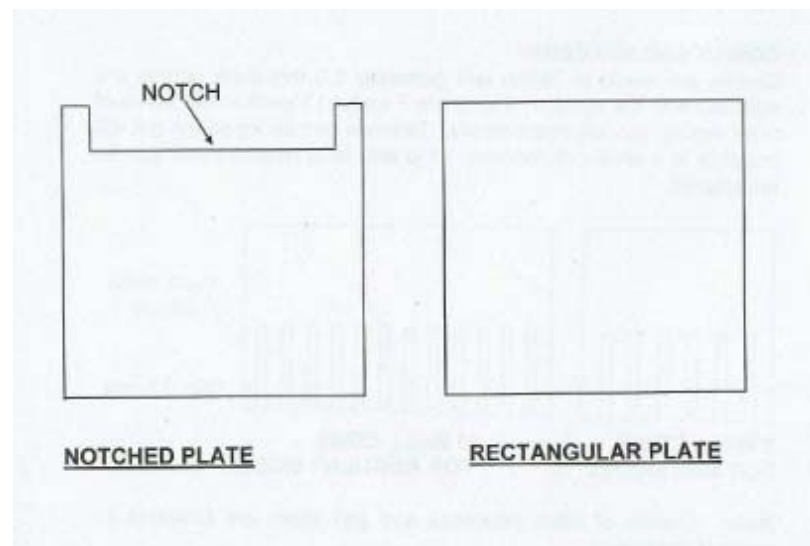

COMBS AND SPACERS:

Combs are made up of Teflon and generally 1.0mm thick combs are supplied with the system. There are 7 Wells/13 Wells in the comb of mini/regular models respectively. Teflon is non sticky so the gel will not stick it while polymerizing. It is also heat resistant and can be autoclaved.

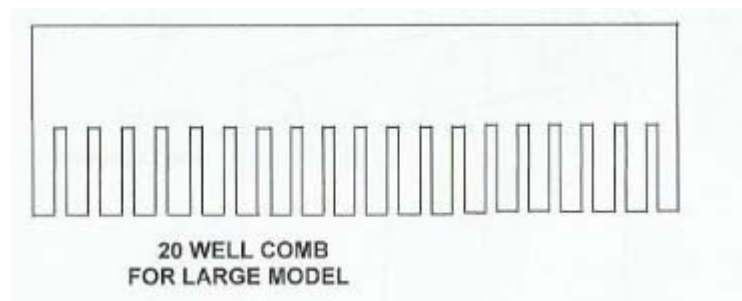

Note: Combs of other thickness and well sizes are available on request separately .

Spacers: Spacers made of Acrylic and of 1.0 mm thickness are generally supplied with the system. They are made 0.05 mm thicker than the combs so that comb can be inserted in the glass sandwich easily.

CATHODE CHAMBER CUM HEAT EXCHANGER :

This is vital unit in the system, It-

- Houses electrodes
- Holds glass plates and
- Controls the temperature

It is a rectangular chamber with the bottom closed for water circulation through the In/outlets provided on the either side .

The side walls of heat exchanger are made of thin acrylic sheet for efficient transfer of heat. Holes with thread are provided for clamping glass plates on either side.

Unlike the bottom part, the top part of the heat exchanger is open. Its sides are notched. When the glass plates (with the gel sandwich) are mounted on either side of heat exchanger, the top portion of heat exchanger form a closed trough - CATHODE CHAMBER. Since there are rubber gaskets on either side of notch, buffer poured in the trough doesn't leak.

Platinum wire running at the center of the cathode chamber acts as cathode (Black). Its terminal is at the top. Similarly, the wire running at the bottom of the heat exchanger is connected to a separate terminal at the top forms anode (Red).

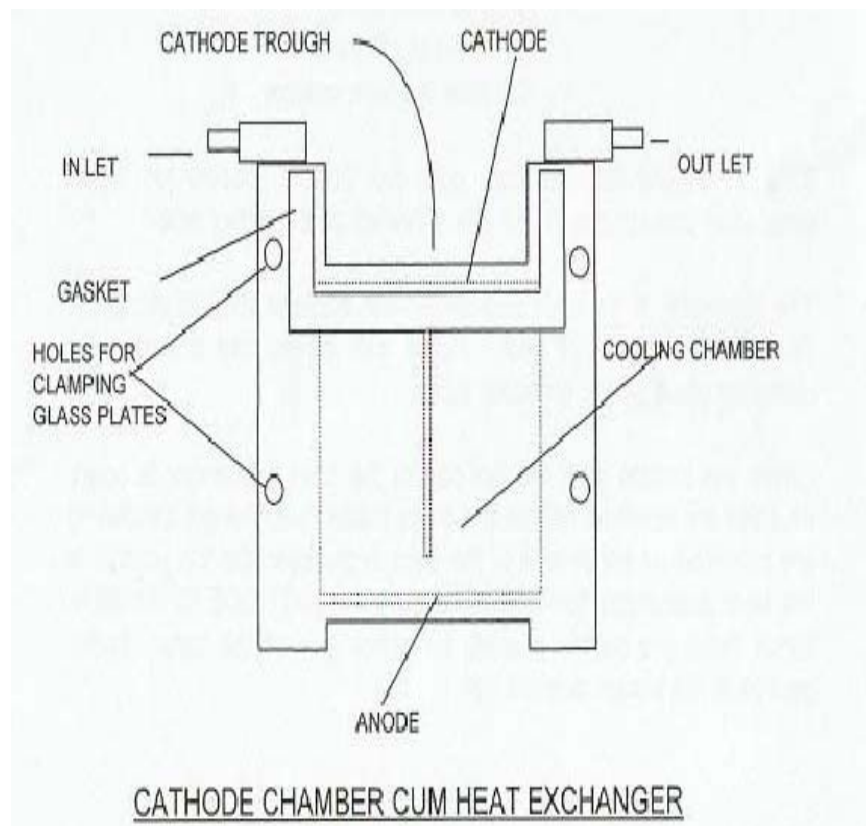

ANODE BUFFER RESERVOIR WITH LID:

It is a large compartment for housing the cathode chamber cum heat exchanger with glass plates on either side. Buffer should be poured to submerge the bottom of the gels. In case the temperature is not critical, lesser volume of buffer can be used.

The lid is made of 3 mm thick acrylic sheet. It covers and protects the basic unit from electric shocks during the run. It also controls buffer from evaporation.

